

HEALEY & LORD  
CLASSIC COLLECTION  
CONCEALED THERMOSTATIC  
SHOWER SET WITH  
HANDSHOWER

HL3500



INSTALLATION GUIDE

# HEALEY & LORD HL3500 - INSTALLATION GUIDE

## DIMENSIONS

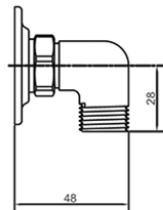
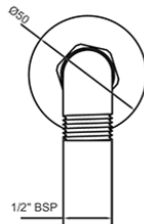
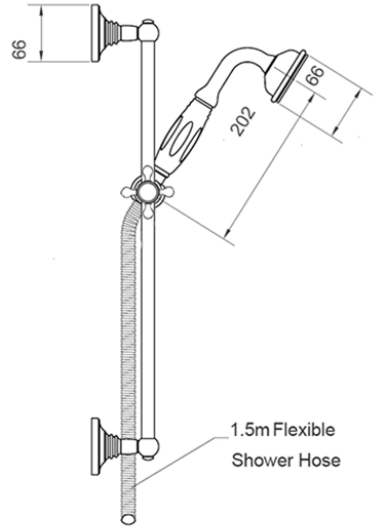
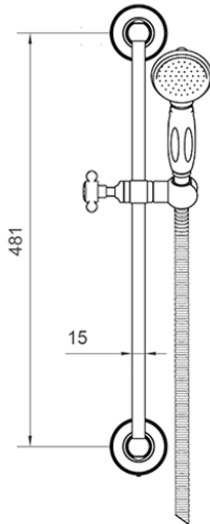
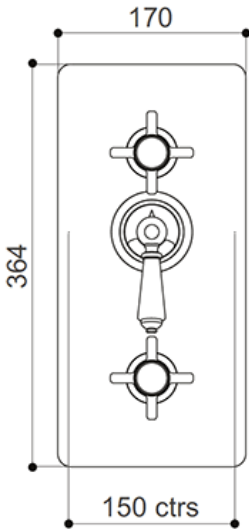
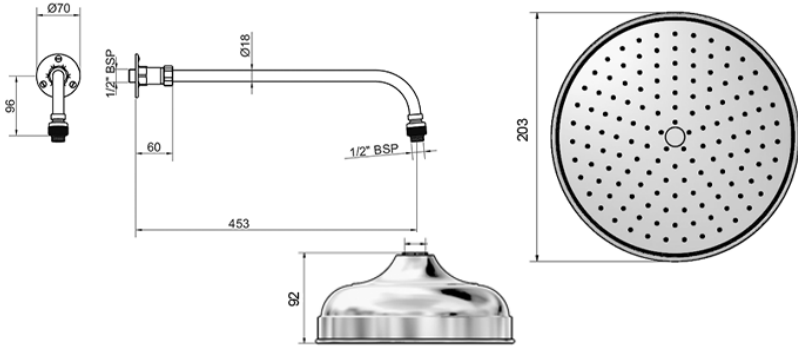

## NOTES

The shower valve should have isolating valves fitted for servicing purposes.

The hot supply should be to the left, and the cold supply to the right when viewed from the front. This is indicated by coloured dots adjacent to the inlet tails, red for hot - blue for cold. The information plate on the back of the thermostatic shower valve also indicates this and the serial number.

The thermostatic shower valve is suitable for connecting to gravity feed, high pressure, low pressure, pumped systems and unequal pressure. The cold water pressure should not be greater than 10 times the hot water pressure. The following alternative water supply requirements should be met;

- **Gravity Feed (Balanced Supplies)**

The cold water is fed directly from the cold water storage tank, which also supplies the hot water cylinder. The distance between the bottom of the cold water tank and the shower head must be a minimum of 1 metre (0.1 bar). For good performance, we suggest the shower head be at least 2 metres below the bottom of the cold water tank. Pipe runs for these supply conditions should be short and in 22mm pipe.

- **Unequal Pressures (Gravity Hot & Mains Cold)**

Cold mains to be a maximum of 5 bar when used in conjunction with a minimum of 1 metre (0.1 bar) head on the hot side. The orifice plate supplied should be installed in the cold supply under these conditions.

- **Unvented Systems (Vented Thermal Store Units, Instantaneous Gas Heaters and Combination Boilers)**

These systems should be capable of delivering hot water at 65°C at a rate of 6 Litres per minute at least.

- **Pumped Showers**

The pump manufacturer's installation instructions should be carefully followed. A pumped system should never be used with mains pressure supplies.

This thermostatic shower valve should be installed in compliance with the water bylaws. For details, refer to the latest copy of the Water Bylaws Guide or your local Water Authority.

The inlet elbows of the thermostatic shower valve include single check valves.

# HEALEY & LORD HL3500 - INSTALLATION GUIDE

## DIAGRAM

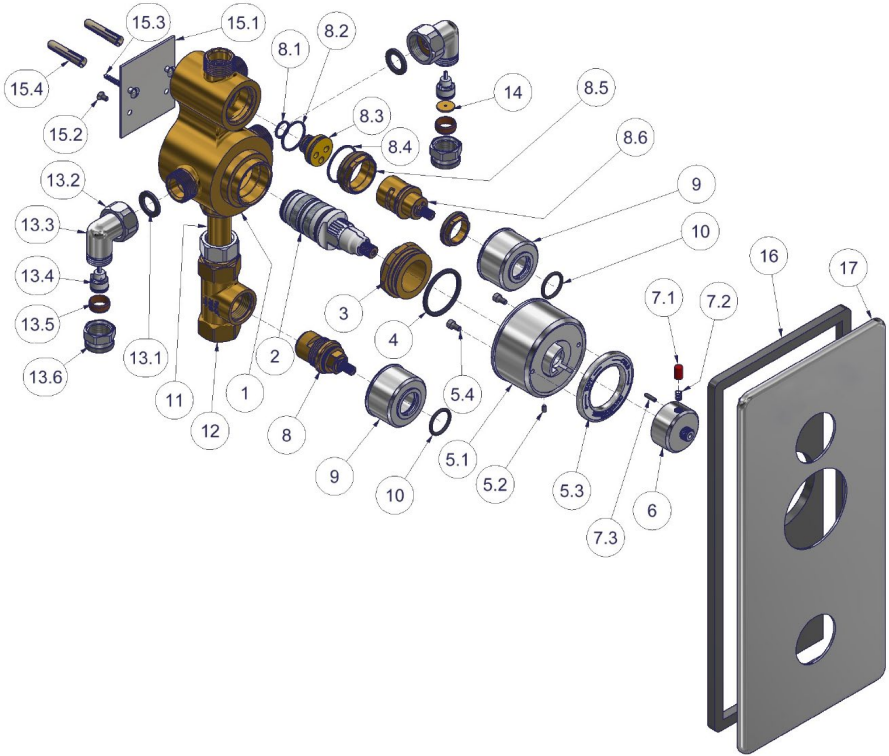

# HEALEY & LORD HL3500 – INSTALLATION GUIDE

## INSTALLATION

Before connecting the thermostatic shower valve, water should be flushed through the pipework for 15 minutes to remove ALL debris and solder flux. The pipework centres are 150mm and the recess in the wall should be 64 to 78 mm deep when measured to the tiled surface. Use the valve to mark the position of the fixing screws.

The thermostatic shower valve should be mounted vertically so that when the concealing plate (17) is fitted the thermostatic shower valve is aligned correctly with any upright or horizontal lines in the bathroom/shower room installation.

1. Drill and plug the wall to suit, using plugs and screws (15.4, 15.3).
2. Connect the swivel elbows (13.3) to the body of the thermostatic mixer valve and the feed pipes. The hot feed pipe is on the left and the cold feed pipe is on the right when looking at the front of the thermostatic shower valve.
3. Tighten the compression nuts (13.6) to obtain a water tight seal.
4. Fit shower connection to the outlet thread on the top of the valve. This thread is standard  $\frac{3}{4}$ " BSP and may require an adaptor to suit chosen pipework system.
5. Test operation of the valve and ensure water-tightness.

## OPERATION

The top handle is an on/off and diverter handle, the centre position is off, turn  $\frac{1}{4}$  turn clockwise to obtain full flow from the top outlet or  $\frac{1}{4}$  turn anticlockwise for full flow from the side outlet.

Temperature is controlled by the lower handle up 38°C where the red over-ride button has to be depressed to obtain a higher temperature up to approximately 45°C. This maximum temperature may be adjusted to suit user requirements as detailed on the following page (amount increased over maximum will also apply to the "38°C position") – move the handle anticlockwise for hotter, and clockwise for colder.

## MAINTENANCE

### Adjusting the Maximum Temperature

1. Turn handle until red button is at the 3 o'clock position.
2. Remove handle as detailed in the Maintenance section.
3. Pull off temperature control.
4. To increase maximum temperature, replace temp control (6) 2 spline grooves (2.5° C) towards cold (i.e. clockwise).
5. To decrease maximum temperature, replace temp control (6) 2 spline grooves (2.5° Celsius) towards hot (i.e. anticlockwise).
6. Replace handle and check required maximum temperature.

### Remove a Lever Handle

1. Pull out the cover button (2.4).
2. Use a screwdriver to remove screw (2.2).
3. Pull off the handle (3.1).



### Remove a Cross Handle

1. Unscrew the index assembly (4.2, 4.3, 4.4).
2. Use a screwdriver to remove screw (1.2).
3. Pull off the handle (4.1).

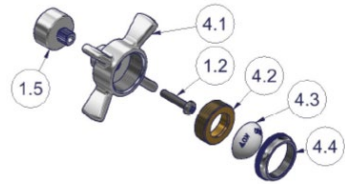

### Remove a Ceramic Disc Valve

1. Isolate hot and cold supplies.
2. Remove handle as detailed in the Maintenance section.
3. Unscrew cover (9) to reveal the headwork mechanism (8.6).
4. Remove complete headwork with on/off handle after loosening with spanner or socket, inspect for damage or debris. Ensure that the spindle rotates easily and opens and closes the ceramic disc apertures. Debris

## HEALEY & LORD HL3500 – INSTALLATION GUIDE

can be flushed away but if damage has occurred a new complete mechanism (8) will be required.

To reassemble; reverse the above procedures ensuring that the mechanism is firmly tightened. The full rotation of this handle is 90°.

### Remove a Thermostatic Cartridge

1. Isolate hot and cold supplies and put temperature handle at 3 o'clock position.
2. Remove handle as detailed in the Maintenance section.
3. Pull off temp control (6).
4. Undo grub screw (5.2) and pull off shield (5.1).
5. Unscrew cartridge fixing nut (3). Being careful not to rotate brass spline of cartridge (2).
6. At this point it is advisable to mark the cartridge (2) brass spline with marker pen in line with the top of the cartridge.
7. Carefully pull-out the cartridge (2).
8. Inspect the inside of the body and the cartridge for signs of debris. Debris can be flushed away and the cartridge filters gently cleaned with a soft brush. The cartridge has no user serviceable components and is not to be dismantled, but can be soaked in a suitable descaler.

To reassemble

1. Lightly lubricate the "O" rings with silicon grease. Carefully push the cartridge back into the body with the groove uppermost and previously marked spline in line. Care should be taken with this operation to ensure that there is no damage to the 'O' rings.
2. Tighten the cartridge fixing nut (3). This must not be over tightened. A force of not more than 15nM should be applied.
3. Reverse the removal operations 8 to 2 to fully reassemble the valve.
4. When reassembled check for water-tightness and operation as detailed previously.

## TROUBLESHOOTING

Every thermostatic shower valve is fully tested before leaving the factory and the following causes should be checked and eliminated before dismantling or servicing the thermostatic shower valve.

- Installation instructions are fully complied with.
- Water supplies instructions are fully complied with.
- Check valves (13.4) in the elbows are clear of debris.

If the valve has been operating correctly for a time, but no longer performs acceptably, it may require servicing.

1. If the ON-OFF / diverter control does not shut off positively, the ceramic disc valve should be inspected for signs of debris or damage.
2. If the valve does not control the temperature correctly it may be necessary to service/clean the temperature control cartridge, and there are screen filters on the cartridge which may, after a period of time, require cleaning.

## AFTER INSTALLATION

After installation, we strongly recommend that the fitting be securely covered to prevent contamination or damage by any form of building materials such as paint, plaster, tile adhesive, grout or sealants until all building and finishing work is completed.

## CLEANING

Shower condition should be maintained by wiping with a soft, damp, clean cloth regularly, and polishing using a soft, dry duster. Do not use abrasive cleaning products or polishes, or abrasive materials such as scouring pads.